

# Data sheet

## Consolidation Point Prefab 6xLC-Q APC OS2

Page 1/5

P/N

1503007A06-E

EAN 4251122197147

2025/09/18

Version: U

### Illustrations



Dimensional drawing

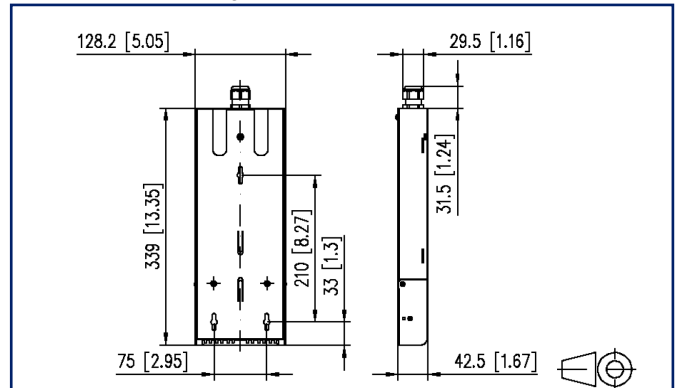

See enlarged drawings at the end of document

### Product specification

- Consolidation Point Prefab with LC-Q adapters
- To connect pre-terminated installation cables Prefab with max. 24 fibers
- Wall-mount powder-coated steel-sheet housing, (white, RAL 9010)
- Patch area with swing-open and removable cover with label field
- Possibility for strain relief for patch cord
- Not used cutouts are closed by blind plugs
- Cable management area with separate cover
- Possible cable entry on the back side for one PG16 cable gland
- If necessary order extensions or reductions for the fixing of the Prefabs as separate accessory
- Supplied with material for wall-mounting
- Variants: equipped with 6 LC-Q adapters lime green (OM5), violet (OM4), aqua (OM3), blue (OS2) or green (OS2 APC)



# Consolidation Point Prefab 6xLC-Q APC OS2

P/N

1503007A06-E

EAN 4251122197147

2025/09/18

Version: U

## Technical Data

### General Data

Fields of application	structured building cabling office areas fiber to the desk data center
Mechanical measurement according to MICE	M1
Ingress measurement according to MICE	I1
Climatic measurement according to MICE	C1
Electromagnetic measurement according to MICE	E3
Transmission technology	Fiber optic
Color	green
Dimensions	
Dimension (L x W x H)	128.2 mm x 29.6 mm x 339 mm
Dimension (L x W x H)	5.047 in. x 1.165 in. x 13.346 in.
Fiber class	OS2
Mode type of the fiber	Singlemode
Labeling option	label strip / labeling strip

### Connections/interfaces

Connector technology interface 1	LC-Q Couplers
Connector technology interface 2	LC-Q Couplers
Number of ports interface 1	6
Number of ports interface 2	6
Number of equipped ports interface 1	6
Number of ports interface 2 equipped	6
Number of ports with dust protection interface 1	6
Number of ports with dust protection interface 2	6
Cable access/outlet	possibility for cable entry on the back

### Mechanical data

Connector type	quad
Life - Number of mating cycles	min. 1000
strain relief	yes

**Consolidation Point Prefab 6xLC-Q APC OS2**

P/N

1503007A06-E

EAN 4251122197147

2025/09/18

Version: U

**Technical Data****Materials and material properties**

Material - Housing	sheet steel
Material - Housing finish	powder-coated
Material - Sleeve	ceramic, slotted
Halogen free	yes
RoHS	compliant

**Standards/Regulations**

FO connector interfaces	IEC 61754-20
-------------------------	--------------

**Classifications**

ETIM 7.0	EC001130
ETIM 8.0	EC001130
ETIM 9.0	EC001130
ETIM 10.0	EC001130

**Packing details**

Type of packaging	1 pc(s) / box
-------------------	---------------

**Application note**

This product is a standard product of METZ CONNECT. METZ CONNECT is not aware of the specific intended use of the goods by the Customer or any customers of the Customer. The Customer guarantees that it has fully and sufficiently tested the use of the goods and any product modifications, product changes or product enhancements with regard to the specific intended use in accordance with the state of the art or in any other way. At METZ CONNECT's request, the Customer shall submit and make available meaningful evidence (e.g. test and laboratory protocols, certifications, etc.).



Data sheet

Page 4/5

**Consolidation Point Prefab 6xLC-Q APC OS2**

P/N

1503007A06-E

EAN 4251122197147

2025/09/18

Version: U

**Accessories**

P/N	Designation
150811P1611-E	Thread reducer PG16 to PG11
150811P1613-E	Thread reducer PG16 to PG13.5
150811P1621-E	Thread enlarger PG16 to PG21
15090401-E	OpDAT crimp splice protection (12 pieces)
15090401-I	OpDAT crimp splice protection (150 pieces)



# Consolidation Point Prefab 6xLC-Q APC OS2

P/N

1503007A06-E

EAN 4251122197147

2025/09/18

Version: U

## Illustrations

Dimensional drawing

